

Diesel Powered Generating Sets

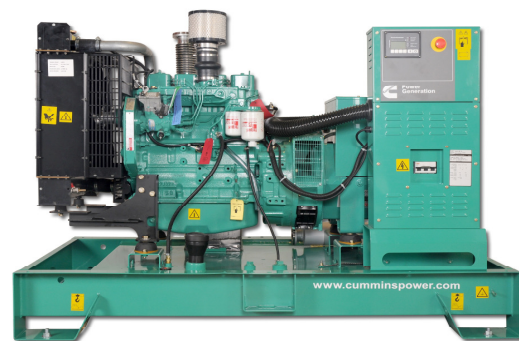

C170D6

Our energy working for you.™



Standard Genset Features

Cummins water cooled Diesel engine.
 Oil and fuel filter fitted, water separator.
 Lube-oil drain valve fitted.
 Electric starter and Charge alternator 24 VDC.
 Electronic governor,
 Normal duty air filter.
 Single bearing alternator.
 Exhaust silencer - industrial (9 dB).
 Set mounted starting battery.
 Engine, Alternator, Chassis and Control Command House color: Munsell Jade Green.
 Radiator and Guarding in color: Black.
 Packing under shrunk plastic film.
 Operation and Maintenance manual.
 Standard set of labels.

PMG (Permanent Magnet Generating)

Offers enhanced motor starting and fault clearing short circuit capability.

Exhaust Options

Exhaust silencer - residential 29 dB(A)

Generator Set Performance

Voltage Regulation

Maintains voltage output within $\pm 1,0\%$ in the following conditions:

1. At any power factor between 0.8 and 1.0
2. At any load level from no load to full load.
3. At any engine temperature.
4. At speed droop variations up to 4,5%.

Frequency Regulation

Isochronous under any load from no load to 100% full load when electronic governor is fitted.

Random Frequency Variation

Will not exceed $\pm 0,25\%$ of rated frequency value for constant loads, no load to full load.

Alternator Temperature Rise

Insulation System - Class H

Compliance Standards

To BS4999/5000 pt 99, VDE 0530, UTE5100, NEMA MG1-22, CEMA, IEC 34, CSA A22.2, AS1359, BSS 5514, ISO 3046 and ISO 8528

Alternator Specification

Type

Brushless single bearing, revolving field, four pole, Vacuum impregnation.
 Class H Insulation, IP23 Protection
 IC 01 cooling system.
 Fully interconnected damper winding.
 AC exciter and rotating rectifier unit.
 Epoxy coated stator winding.
 Rotor and exciter impregnated with polyester resin appropriate to the tropical climate, resistant to oil and acids.
 Rotor balanced dynamically BS 5625 2,5 degrees.
 Permanent lubricant ball bearing
 Rotor wound in layers and with mechanics coins.
 Rotor wound in layers and with mechanics coins.

Exciter

Triple dipped in varnish resistant to oil and acid and coated with anti-tracking varnish.

Winding

Low reactance 2/3 pitch windings; low waveform distortion with non-linear loads, fault clearing short-circuit capability.
 Engine/alternator direct coupling for perfect alignment.

Generator Set Options

Options

Coolant heater
 Battery Charger
 Automatic Transfer Switches - GTEC
 Silencer Enclosures

Voltage Connections

480/277 V
 440/254 V 380/220 V 220/127 V
 416/240 V 240/139 V 208/120 V

Fuel Consumption (l/h)

Rated Power	Standby				Prime			
	212 kVA		170 kW		206 kVA		165 kW	
Load	Full	3/4	1/2	1/4	Full	3/4	1/2	1/4
Fuel Consumption (l/h)	53	48	35	24	48	35	24	14

P.S.:

The engine was tested according with ISO-3046, considering the following conditions:

Barometric Pressure = 100 kPa (29.53 in Hg)

Altitude (above sea level) = 110 m (316 ft)

Ambient Temperature = 25° C (77° F)

Relative Humidity = 30%

Technical Data

Model	C170D6	Alternator voltage regulation	± 1,0%
Standby Rating	212 kVA / 170 kW	Alternator insulation class	H
Prime Rating	206 kVA / 165 kW	IP Protection	IP 23
Engine Make	Cummins	Fuel consumption (Standby)	53 l/h
Engine Model	6CTA 8.3-G2	Fuel consumption (Prime)	48 l/h
Cylinders	6 cylinders	Lubrication system oil capacity	23,8 liters
Engine Build	In line	Coolant capacity (only engine)	12,3 liters
Standard Governor/Class	Mechanical	Coolant capacity (engine and radiator)	35,6 liters
Aspiration and cooling	Turbocharged	Exhaust temperature (Prime)	513°C
Bore and stroke	114 mm x 135 mm	Exhaust gas flow (Prime)	660 l/s
Compression Ratio	16,8 : 1	Exhaust gas back pressure max	76 mm Hg
Cubic capacity	8,3 liters	Air flow radiator	-
Starting/Min °C	Unaided / -12°C	Intake air flow	255 l/s
Battery capacity	100 A/h	Minimum air opening to room	-
Gross Engine output – Standby	207 kWm	Minimum discharge opening	-
Gross Engine output – Prime	188 kWm	Radiated heat to ambient	29 kWm
Speed	1800 rpm	Tank incorporated in the base capacity	250 liters

STANDBY POWER

The Standby Power Rating is applicable for supplying emergency power for the duration of a utility power interruption. No overload, utility parallel or negotiated outage operation capability is available at this rating. In installations served by unreliable utility sources (where outages last longer or occur more frequently), where operation is likely to exceed 200 hours per year,

PRIME POWER

Prime power is available for an unlimited number of annual operating hours in variable load applications, in accordance with ISO8528-1.

A 10% overload capability is available for a period of 1 hour within a 12-hour period of operation, in accordance with ISO 3046-1.

Todas as potências dos Grupos Geradores são baseadas nas seguintes condições de referência:

Ambient Temperature = 25° C (77° F)

Altitude (above sea level) = 110 m (316 ft)

Relative Humidity = 30%

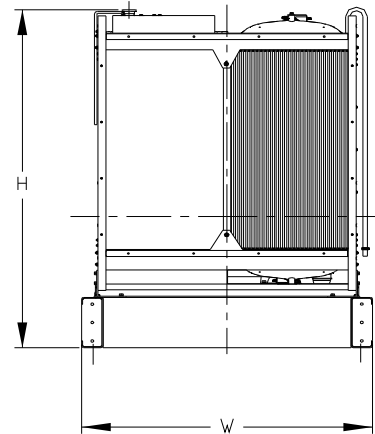
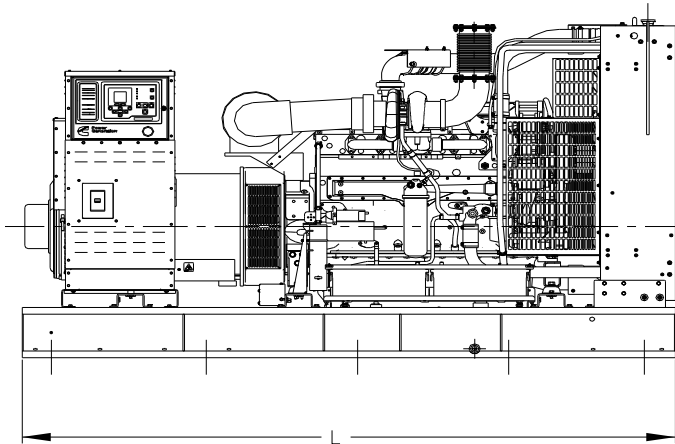

Dimensions and Weights

Genset	Length (mm)	Width (mm)	Height (mm)	Set weight dry (kg)	Set weight wet (kg)
	L	W	H		
Open Set	2700	1360	1763	1859	1914
Carenagem - 85 dB(A)	3896	1414	2315	2708,1	2716,8
-	-	-	-	-	-



Cummins Brasil Ltda.
Rua Jati, 310 - Cumbica
Guarulhos - SP - Brasil
Zip Code: 07180-900
Phone: (55 11) 2186-4195
www.cumminspower.com

the
Power
of One

See your distributor for more information.

