

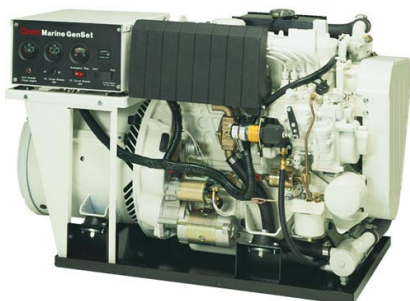

Onan MARINE GENERATORS



17 kW 60 Hz
13.5 kW 50 Hz
MDKA Series
Model MDKAD
Diesel

Leading the Way

- Rugged dependability and high quality features make Onan a leading name in the marine industry. Reliable Onan marine generator sets have more standard features than any other marine genset available.
- Onan leads the way in innovation, with a sophisticated design and development process that applies technology to noise attenuation, vibration isolation and emissions. These technologies provide quiet, smooth running and clean gensets for your boating pleasure. Onan marine gensets are emissions certified per applicable regulations including CARB and EPA.
- The Onan designed and manufactured high efficiency, brushless alternator delivers the power you need with excellent load response and AC output characteristics. This alternator is protected with corrosion-resistant resins for salt water environments.
- Onan marine gensets are designed for compliance with U.S. Coast Guard regulations and ABYC voluntary standards, developed to increase your boating enjoyment.
- Onan marine gensets are produced by Cummins Power Generation, a subsidiary of Cummins Inc. Onan gensets are supported by the largest worldwide certified Distributor/Dealer network in the industry. Our extensive warranty coverage provides owner peace of mind.
- Onan gensets are complemented by a full line of accessories, making it easy to customize an Onan genset to suit your application. Onan gensets are easy to install, operate and maintain, plus they are small in size.
- More than 60 years of marine experience, gained by supplying gensets to the U.S. Coast Guard, Navy, recreational boaters and some of the finest yacht builders in the world, stand behind every Onan marine genset.

Genset Ratings

Model	kW/kVA	Voltage	Amps	Phase	Hz	Engine RPM
17MDKAD	17/17	120/240	141.7/70.8	1	60 Hz	1800
13.5MDKAD	13.5/13.5	110/220	122.7/61.4	1	50 Hz	1500
		115/230	117.4/58.7	1	50 Hz	1500
		120/240	112.5/56.3	1	50 Hz	1500

Three phase and other single phase configurations are available, contact your Distributor/Dealer for more information. Rating conditions are 100 kPa (29.6 in Hg) barometric pressure, 30% relative humidity and 25° C (77° F) (ref. ISO 3046).

Genset Dimensions and Weights

	Without Sound Shield	With Sound Shield
Length	40.4 in (1027 mm)	44.3 in (1126 mm)
Width	20.4 in (519 mm)	23.7 in (602 mm)
Height	26.4 in (671 mm)	28.8 in (731 mm)
Weight (dry)	775 lb (352 kg)	905 lb (411 kg)

Features

- Switchable between 50/60 Hz
- Single phase AC alternator with single or dual voltages, brushless
- Solid state voltage regulator
- 300% short circuit current capability
- 12 V DC electric system with battery charging, negative ground
- DC control console mounted with isolation and DC protective circuit breakers
- Start-run-stop switch with glow plug pre-heat and fuel pump priming modes for easy starting
- Electric fuel transfer pump for priming and lift capability
- Engine starter with automatic start disconnect
- Freshwater cooling system with heat exchanger, expansion tank and coolant recovery system
- Water cooled exhaust mixing elbow
- Gear-driven raw water pump
- AC mainline circuit breaker
- Field circuit breaker
- Manual reset fault circuit breaker indicates engine shutdown for
 - High engine coolant temperature
 - High exhaust temperature
 - Low oil pressure
 - Over speed
 - Over voltage
 - Additional customer input
- Running time meter
- Air intake silencer
- Full flow lube oil filter
- Oil drain and hose extension
- Electric fuel shut-off solenoid
- Fuel filter/water separator
- Drip pan base capable of containing all genset fluids
- Captive focalized mounting system with vibration isolator mounts
- Single point lifting bracket for ease of installation
- Plug-in watertight connector for optional remote control
- Closed crankcase breather re-circulation to eliminate engine room contamination
- Coolant overflow bottle to easily maintain coolant level
- Factory load tested
- E-coat process to protect sheet metal
- Five year Limited Warranty
- DNV Type Approval

Available Options

- DC gauge package with voltmeter, temperature gauge, oil pressure gauge and senders; set-mounted, negative ground or isolated ground versions available
- 3 phase, 125° C broad range alternator with a variety of voltages
- Low coolant level shutdown
- Keel cooling with wet exhaust
- Keel cooling with dry exhaust, up or down orientation
- 12 V DC electric system with battery charging, isolated DC
- 24 V DC electric system with battery charging, negative ground
- 24 V electric system with battery charging, isolated DC
- Front power take-off (PTO) for full engine output with clutch, flexible coupling and SAE B flange pump mounting for 2 and 4 bolt mounting; (12 or 24 V DC clutch)
- Sound shield housing



Onan Optional Sound Shield

Accessories

- Basic remote start/stop switch
- Deluxe remote start/stop switch with hourmeter
- Deluxe remote start/stop switch with DC voltmeter
- Dual gauge momentary switch to allow operation of remote panel gauges and set mounted gauge panel
- Sound shield housing
- Remote station harness pigtail
- Remote panel wire harness - 15 ft, 25 ft, 45 ft, 75 ft, 100 ft or 150 ft
- Remote gauge package with start/stop switch, hourmeter, DC voltmeter, oil pressure and water temperature gauges; select appropriate sender kit for negative ground or isolated DC
- Line circuit breakers for field conversion of frequency or AC voltage output
- Remote fuel filter/water separator assembly
- Dry exhaust muffler, flexible exhaust stainless steel tube assembly
- Siphon break kit
- Wet exhaust hose
- Battery
- Low coolant level safety shut-off switch
- Marine muffler & water separator - dual silencers
- Front power take-off (PTO) for full engine output with clutch, flexible coupling and SAE B flange pump mounting for 2 and 4 bolt mounting; (12 or 24 V DC clutch), additional sound shield front panel or belt guard is required
- Cruise kit - maintenance parts - fuel filters, oil filters, sea water pump impellers, zinc pencils and alternator belt, plastic container



Optional Cruise Kit

Outline Drawing

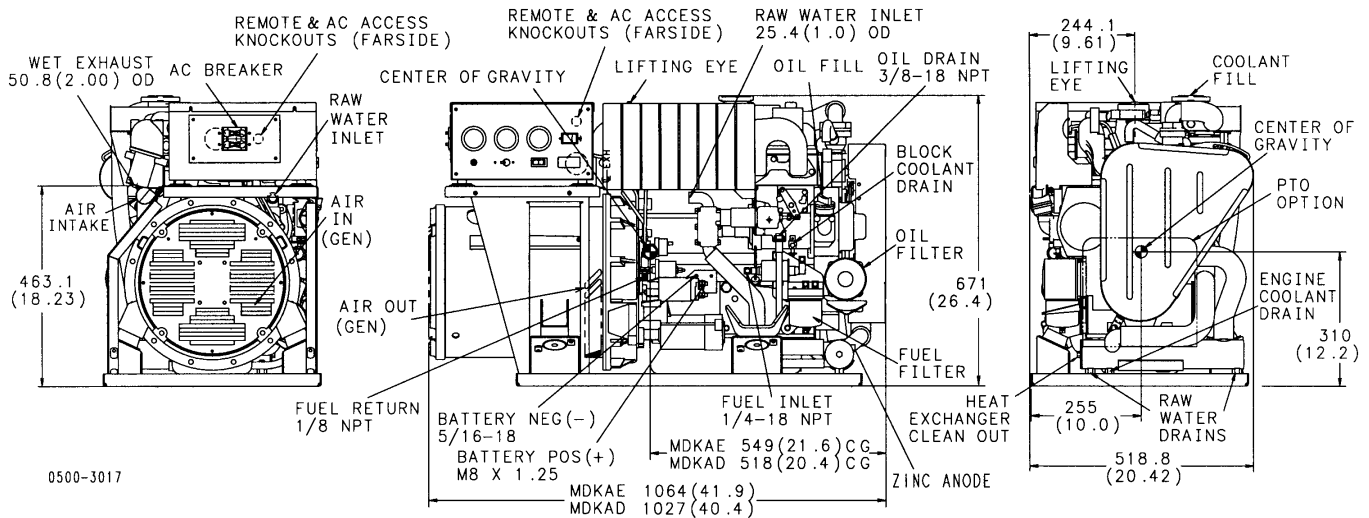

This outline drawing is provided for general reference only and is not intended for design or installation. See installation manual and obtain outline drawing number 500-3017 for more information (available from your Distributor/Dealer).

Engine Detail

Design 4-cycle, water-cooled diesel
Cylinders 4
Bore 3.15 in (80 mm)
Stroke 3.64 in (92.4 mm)
Displacement 113.32 in³ (1857 cm³)
Compression Ratio 23:1
Max Fuel Lift 4 ft (1.22 m)
Lube Oil Capacity 8 qt (7.6 L)
Coolant Capacity 8 qt (7.6 L)
Coolant Flow Rate
 60 Hz: 14.0 Gal/min (53.0 L/min)
 50 Hz: 10.0 Gal/min (37.9 L/min)

Raw Water Flow Rate
 60 Hz: 9.0 Gal/min (34.1 L/min)
 50 Hz: 7.0 Gal/min (26.5 L/min)
Starting System Remote 3-wire, 12 V, starting battery 12 V 70 Ah, 500 CCA @ 0° F (-18° C) minimum; 24 V optional
Power (Max) SAEJ1349
 at 1800 RPM 31.2 hp (23.3 kW)
 at 1500 RPM 26 hp (19.4 kW)
Fuel Injection Pump Bosch PFR-M mini
Combustion Chamber Spherical, three vortex combustion system

Max Raw Water Lift 4 ft (1.22 m)
Fuel Consumption
 No. 2 diesel fuel, Gal/hr (L/hr)

	13.5 MDKAD	17 MDKAD
No Load	0.3 (1.1)	0.4 (1.5)
1/4 Load	0.5 (1.9)	0.6 (2.3)
1/2 Load	0.7 (2.7)	0.8 (3.0)
3/4 Load	0.8 (3.0)	1.0 (3.8)
Full Load	1.1 (4.2)	1.3 (4.9)

Alternator Detail

Design Onan brushless, revolving field, 4-pole alternator; rigidly coupled to engine and permanently aligned
Voltage Regulator Solid state Onan SR regulator, circuit board encapsulated for corrosion protection; integrated heat sink for high engine room temperatures

Exciter System Brushless with 8-pole stator mounted in endbell; rotating rectifier assemblies are encapsulated for protection from adverse environments
Stator Skewed stator and 2/3 pitch windings minimize field heating and voltage harmonics; resin-coated for corrosion protection

Rotor Dynamically balanced assembly; direct-coupled to engine by flexible drive discs; supported by prelubricated, maintenance-free ball bearing
Cooling Direct drive centrifugal blower
Insulation System Class H per NEMA MG1-1.65 and BS 2757/IEC 60085

Genset Detail

Operating Environment Gensets are durability tested at maximum ambient; air temperature: 176° F (80° C); raw water temperature 100° F (37.8° C)

Frequency Regulation 5% no load to full load
Random Frequency Variation Will not exceed +/-0.5% of its mean value for constant loads from no load to full load
Voltage Regulation No load to rated load +/-1%

Random Voltage Variation Will not exceed +/-1% of its mean value for constant loads from no load to full load
Sound Level
 67 dB(A) at 60 Hz*
 64 dB(A) at 50 Hz*
 * Full load at 1 m with optional Onan sound shield

Warranty Policy

The Onan express, written Limited Warranty covers virtually everything except routine maintenance for the first two years you own your marine genset, and covers parts and labor on major power train and genset parts during the third through fifth years.

For complete Onan Limited Warranty details see your Onan Distributor/Dealer.

After Sale Support

GENUINE ONAN MAINTENANCE PARTS AND PRODUCTS - For your ongoing satisfaction and the dependability of your Onan marine genset, Onan offers a complete line of replacement and tune-up parts, accessories and oil and maintenance chemicals. Onan marine parts are packaged for correct selection and convenient on-board storage.

EASY TO LOCATE CERTIFIED ONAN SERVICE AND PARTS DEALERS - Onan has the largest and best-trained worldwide certified Distributor/Dealer network in the industry, offering on-time parts and service and installation assistance. Onan Distributor/Dealers stock and sell commonly used Onan marine genset maintenance parts, accessories and products, plus operator manuals and literature on current Onan gensets. They can help you select and install the right genset for a new vessel or accessories on older models, or provide answers to questions on proper operation and maintenance procedures.

MANUALS - Installation, operators and parts manuals are shipped with the genset. To obtain additional copies or other manuals for this model, see your Onan Distributor/Dealer.

Standards and Testing



DET NORSKE VERITAS

National Marine Manufacturers Association (NMMA) members produce every conceivable product used by recreational boaters. NMMA provides a wide variety of programs and services including technical expertise, standards monitoring, government relations advocacy and industry statistics.

The American Boat and Yacht Council (ABYC) develops standards and recommended practices for designing, constructing, equipping and maintaining small pleasure and commercial craft.

This genset was designed and manufactured in facilities certified to ISO 9001.

DNV Type Approval. DNV is recognized worldwide as a leading provider of classification of marine components.

Contact your Distributor/Dealer for more information



To easily locate the nearest Onan Distributor/Dealer, or for more information, contact Onan at 1-800-888-ONAN or 763-574-5000; 1400 73rd Avenue N.E., Minneapolis, MN 55432 U.S.A.; fax 763-574-5298; e-mail: pgamail@cummins.com; www.onan.com.

©2001 Cummins Power Generation. Cummins Power Generation is a subsidiary of Cummins Inc. Onan is a registered trademark of Cummins Inc.

WARNING: Backfeed to a utility system can cause electrocution and/or property damage. Do not connect to building electrical except through approved device or after building main breaker is open.