



Spark ignited generator set 60 kW standby



Features and benefits

- Extremely quiet operation
- Fully automatic operation when used with a Cummins automatic transfer panel
- Available for use with natural gas or LP vapor
- Attractive and discreet sound attenuated housing
- Electronic governor for precise frequency control
- Includes 120 V coolant heater for cold weather
- Listed to UL 2200
- EPA certified for dual fuel
- Steel enclosure
- IBC and OSHPD seismic certified

Size and sound level

Size: Length 101.5 in (2578 mm),
width 41.3 in (1049 mm),
height 71.8 in (1824 mm)

Sound: 68 dB(A) measured at 7 m, average at
full load with steel enclosure

Models and ratings

Order model	Fuel	Voltage	Phase	Rated kW	kVA	Rated amps	Circuit breaker	Enclosure
GGHE	Natural gas/ Propane	120/240	1	60	60	500/250	300 A, 2 pole	Steel
	Natural gas/ Propane	120/208	3	60	60	361.3/208.4	300 A, 3 pole	Steel

Note: See page 4 of this document for derating factors.

Standard features

Engine:

- Electronic ignition
- Electronic governor
- Full-pressure lubrication
- High-capacity oil sump, spin-on oil filter
- Solenoid shift starter
- 65 A, engine-driven battery charger
- 120 V coolant heater
- Oil drain extension

Control system:

- PCC 2100 control system
- Automatic remote starting
- Controls generator set starting and shutdown
- Control components designed to withstand the vibration levels typical in generator sets
- Field circuit breaker
- High temperature, low oil pressure, low coolant level, overcrank and over speed shutdowns
- Running time meter
- UL Listed circuit breaker
- DC control fuse

Exhaust muffler:

- Enclosed exhaust silencer
- Low noise

Engine details

Engine: Ford industrial, spark-ignited

Design: 10-cylinder V, liquid-cooled

Compression ratio: 9.0:1

Displacement: 415 cu in (6.8 L)

Cooling system: 122° F (50 °C) ambient cooling system

Oil sump capacity, L (qt): 6.1 (6.5)

Operating speed: 1800 RPM

Gross engine power output, kWm (bhp):

Model	Natural Gas	Propane
GGHE	72.7 (97.5)	72.9 (97.7)

Genset weight:

Model	Enclosure	Weight lbs (kg)
GGHE	Steel	2991 (1357)

Average fuel consumption

Fuel consumption – natural gas - GGHE

Load:	1/4	1/2	3/4	Full
Ft ³ /hr	333.2	499.8	656.9	809.2
M ³ /hr:	9.4	14.2	18.6	22.9

Fuel consumption – propane - GGHE

Load:	1/4	1/2	3/4	Full
Ft ³ /hr	138.3	201.0	265.6	328.3
M ³ /hr:	3.9	5.7	7.5	9.3

Alternator details

Design: Brushless, revolving field, 12 lead re-connectable, single phase design.

Insulation system: Class H per NEMA MG1-1.65.

Temperature rise: At rated load is less than 125 °C at standby rating, per NEMA MG1.22.40, IEEE 115 and IEC 34-1.

Exciter type: The excitation system derives its power from the main output of the generator, eliminating the need for a separate excitation power source.

Alternator cooling: Direct drive centrifugal blower.

Rotor: Supported by a pre-lubricated maintenance-free ball bearing.

AC wave form total harmonic distortion: Less than 5% total no load to full load, less than 3% for any single harmonic.

Generator set performance

Governor regulation class: ISO 8528 Part 1 Class G3

Voltage regulation: 1%, no load to full load.

Frequency regulation: Isochronous, 0% no load to full load.

Operating temperature: -20 °F (-28.8 °C) to 122 °F (50 °C).

Motor starting kVA (at 90% sustained voltage):
GGHE: 155

Basic dimensions

Dimensions: mm/in

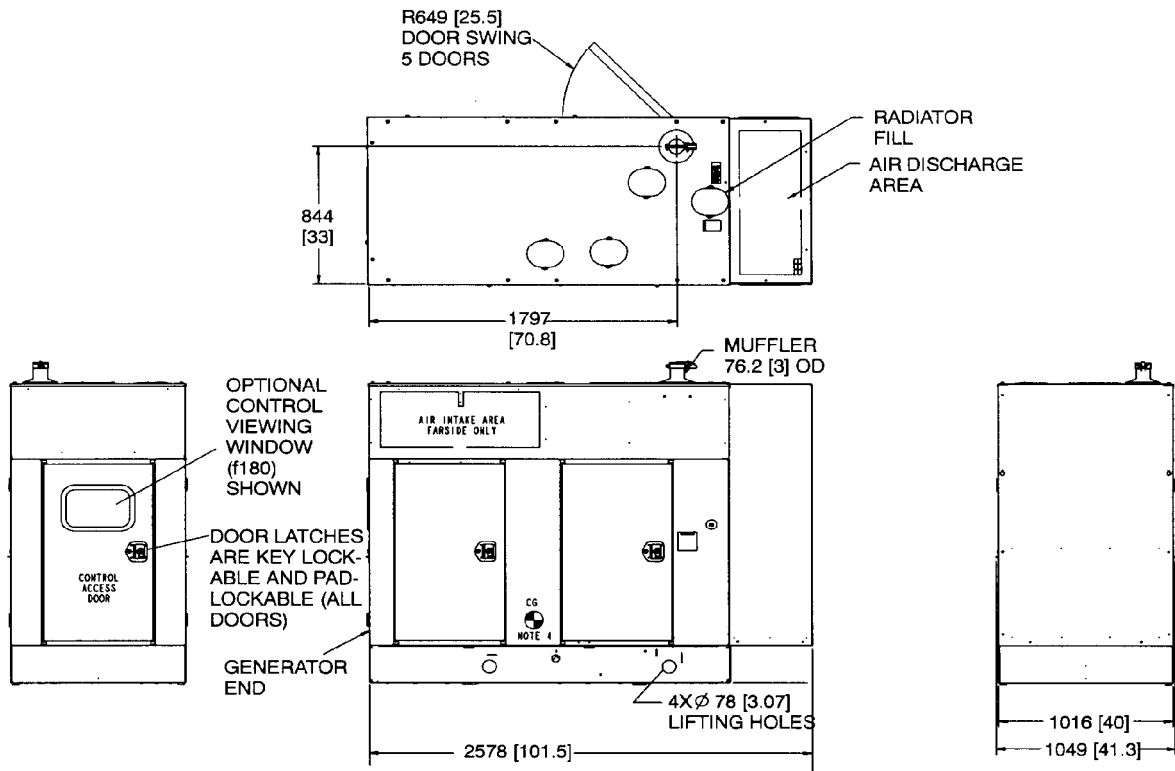

Note: This outline drawing is provided for general reference only and is not intended for design or installation. For more information see Operation and Installation manuals or obtain drawing 500-3167 and wiring diagram from your distributor/dealer.

Automatic transfer panel configurations

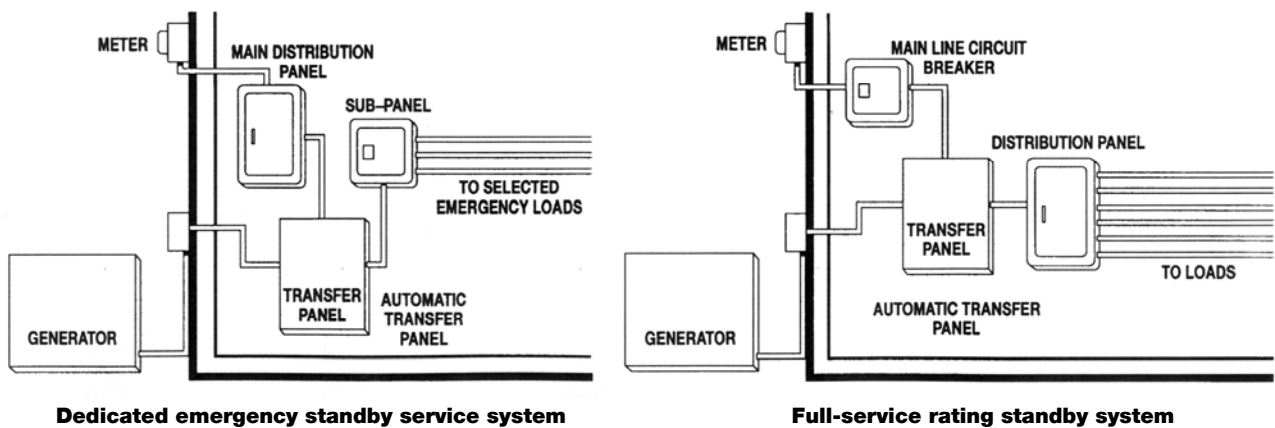

Options and accessories

- Battery, 12 V, 620 cca (P/N 416-0823)
- Battery heater kit (P/N 333-0469)
- Full line of complementing automatic transfer panels

Housing features

- Sound attenuated, weather protective design, key-lockable service access doors
- Internal starting battery tray and tie down
- Heavy-duty steel housing, stainless steel fasteners

Derating factors

60GGHE Model, Natural Gas

Rated power available up to 915 m (3000 ft) at ambient temperatures up to 40 °C (104 °F). Above 915 m (3000 ft) derate at 4% per 305 m (1000 ft), and 2% per 11 °C (1% per 10 °F) above 40 °C (104 °F).

60GGHE Model, Propane

Rated power available up to 1220 m (4000 ft) at ambient temperatures up to 40 °C (104 °F). Above 1220 m (4000 ft) derate at 4% per 305 m (1000 ft), and 2% per 11 °C (1% per 10 °F) above 40 °C (104 °F).

Testing and standards



This generator set is designed in facilities certified to ISO 9001 and manufactured in facilities certified to ISO 9001 or ISO 9002.



The Prototype Test Support (PTS) program verifies the performance integrity of the generator set design. Cummins Power Generation products bearing the PTS symbol meet the prototype test requirements of NFPA 110 for Level 1 systems.



All low voltage models are CSA certified to product class 4215-01.



The generator set is available Listed to UL 2200, Stationary Engine Generator Assemblies. The PowerCommand control is Listed to UL 508 - Category NITW7 for U.S. and Canadian usage.

U.S. EPA

Engine certified to U.S. EPA SI Stationary Emergency Emission Regulation 40 CFR, Part 60.

After sale support

Largest distributor/dealer support network

Cummins generator sets are supported by the largest and best trained worldwide certified distributor/dealer network in the industry. This network of knowledgeable Cummins distributor/dealers will help you select and install the right generator set and accessories to meet the requirements of your specific application. This same network offers a complete selection of commonly used generator set maintenance parts, accessories and products plus manuals and specification sheets. Plus, they can answer your questions regarding proper operation, maintenance schedules and more.

Manuals: Operation and installation manuals ship with the generator set. To obtain additional copies or other manuals for this model, see your Cummins distributor/dealer and request the following manual numbers: Operation (928-0143), Installation (928-0617), Parts (928-0244).

To easily locate the nearest Cummins distributor/dealer in your area, or for more information, visit www.cumminsonan.com or www.cumminspower.com.

Warranty policy

Cummins generators come with a standard two-year warranty. Additional two and five-year warranty options are available. Some restrictions apply.

This product is EPA Emissions certified for emergency standby use only.



WARNING:

Standby rating based on: Applicable for supplying emergency power for the duration of normal power interruption. No sustained overload capability is available for this rating. (Equivalent to fuel stop power in accordance with ISO3046, AS2789, DIN6271 and BS5514.) nominally rated.



WARNING:

Back feed to a utility system can cause electrocution and/or property damage. Do not connect to any building electrical except through an approved device or after building main breaker is open.

Contact your distributor/dealer for more information.

North America
1400 73rd Avenue N.E.
Minneapolis, MN 55432
USA

Phone 763 574 5000
Fax 763 574 5298

Our energy working for you.™

©2015 Cummins Inc. All rights reserved.

Cummins is a registered trademark of Cummins Inc.

"Our energy working for you." is a trademark of Cummins Power Generation. Other company, product, or service names may be trademarks or service marks of others. Specifications are subject to change without notice.

A-1564f (8/15)



power.cummins.com